

DEAN
FRAME PASSPORT

TYPE: 7EO
LAST UPDATE: 27/06/2017

5.2.1. MECHANICAL CABLE ROUTING TOP TUBE ENTRY

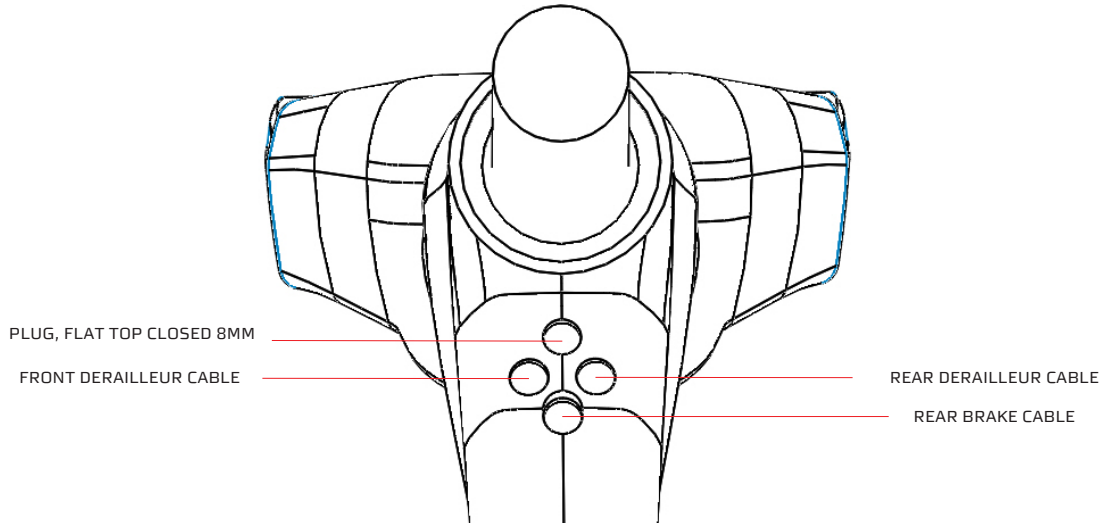

5.3. ELECTRONIC CABLE ROUTING

Below you can find the parts needed for a electronic groupset:

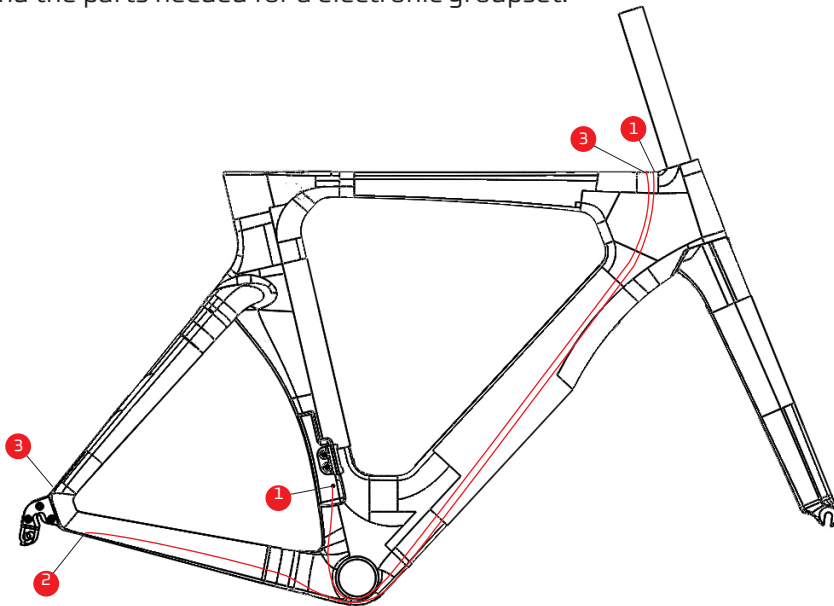

5.3.1. SHIMANO DI2 AND CAMPAGNOLE EPS

NO.	PART	PART CODE	QUANTITY
1	PLUG, FLAT TOP 8 MM	FRPGROJAG003	2
2	PLUG, FLAT TOP 10 MM	FRPGROJAG008	1
3	PLUG, FLAT TOP CLOSED 6 MM	FRPGRORID010	3

5.4. Wireless groupsets

Below you can find the parts needed for a wireless groupset:

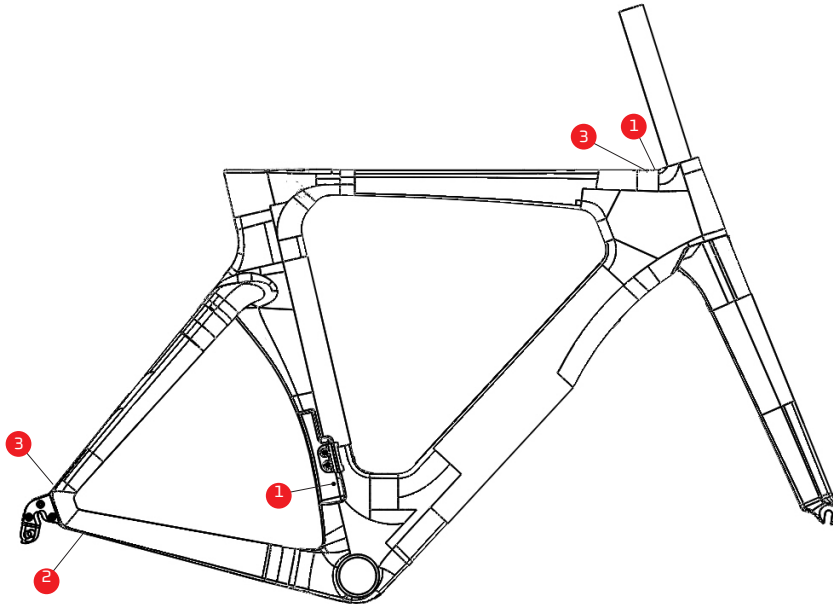

5.4.1. SRAM ETAP

NO.	PART	PART CODE	QUANTITY
1	PLUG, FLAT TOP CLOSED 8MM	FRPGROJAG002	2
2	PLUG, FLAT TOP CLOSED 10MM	FRPGROJAG007	1
3	PLUG, FLAT TOP CLOSED 6 MM	FRPGRORID010	3

5.4.2. WIRELESS GROUPSET TOP TUBE

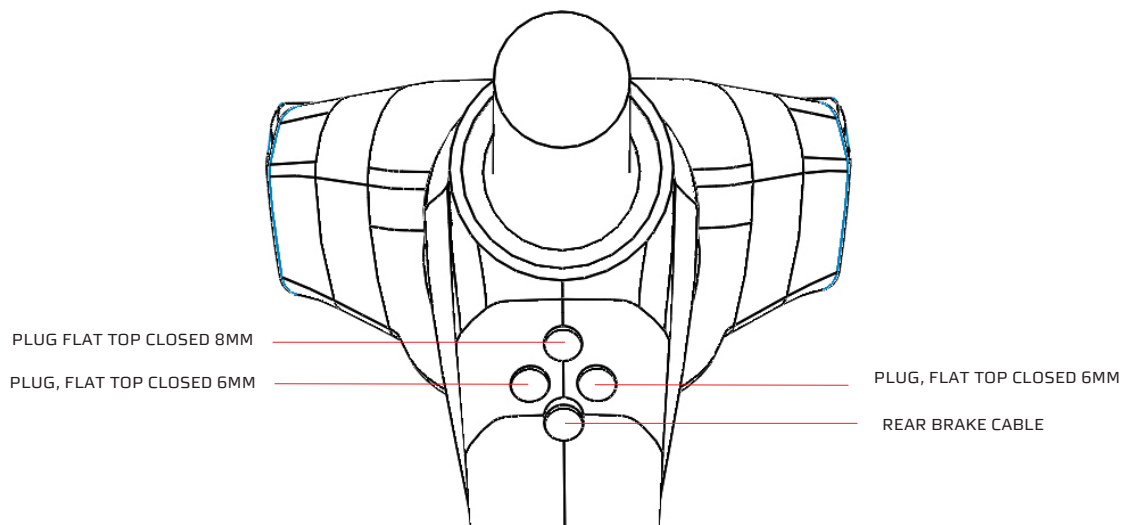

6. PARTS

6.1. FORK

The standard fork, used for a Dean, is the 4ZA Dean fork.

6.1.1. MATERIAL

Fork legs: Carbon
Steerer tube: Carbon

6.1.2. DIMENSIONS

Steerer tube length: 300 mm
Headset: 1 1/8" upper ring – 1 1/2" lower ring
Fork rake: 45 mm
OLD (OverLock nut Distance): 100 mm

6.1.3. PART CODES

All the 4ZA Dean forks have a particular part code composed by the letters "FOROEMRID...", added by 3 numbers. The three numbers, depending on the design. Due to the big amount of forks we don't list all the numbers but you can contact your local dealer for more information if needed.

6.2. HEADSET

45° Oversized angular contact bearing (S.H.I.S. : IS42/28.6 | IS52/40):

Lower bearing: 1 1/2"
Upper bearing: 1 1/8"

Recommended headset:

RIDLEY PART CODE	TYPE	BRAND
HSERACF5A008	NO.42/ACB-A-H6091	FSA
HSERACF5A009	NO.42/CFST/ACB-A-H6091	FSA

6.3. SEAT POST

The Dean is standard assembled with the Ridley aero TT seat post (Part code: SEPAER4ZA...). The sliding mechanism allows you to position the saddle in various positions. The illustration below explains the adjusting mechanism and indicates the utmost mounting positions.

TT/TRI SEATPOST			
POSITION	SEATPOST HEIGHT TO BB MM*	SEAT TUBE ANGLE °	BB DISTANCE MM*
MIN SETBACK (FRONT)	700	77	10
MAX SETBACK (REAR)	1000	73	-150

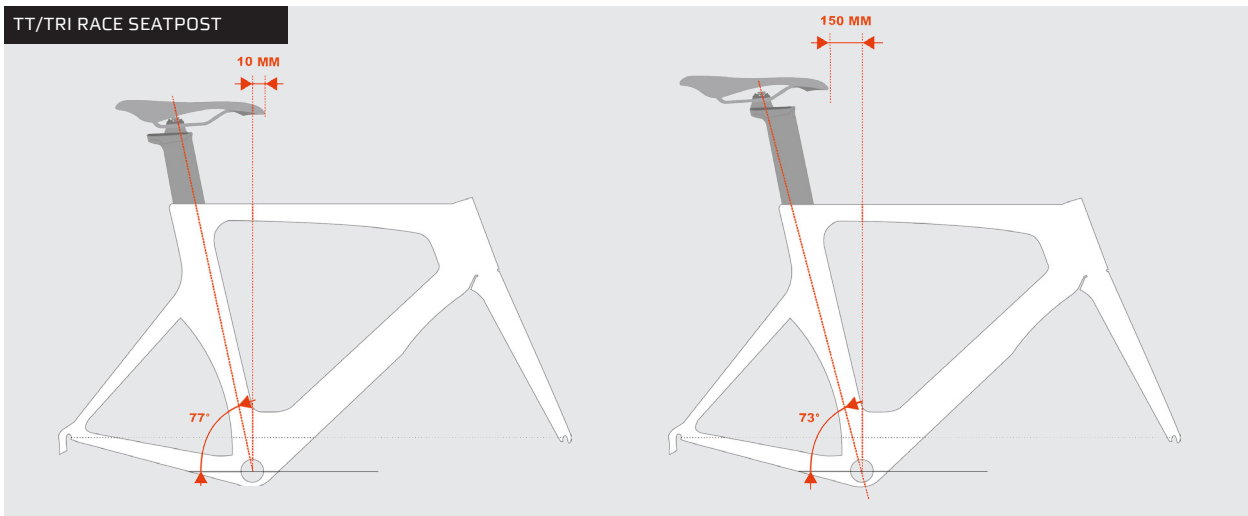

* Calculated based on the dimensions of the 4ZA TT saddle (SADTTRZA001)

! PAY ATTENTION, THE MINIMUM INSERT DEPTH OF THE SEAT POST IS 100 MM.
! PAY ATTENTION, THE MAXIMUM INSERT DEPTH OF THE SEAT POST IS 200 MM, MAXIMUM INSERT DEPTH FOR XXS FRAME SIZES IS 180 MM. INSERTING THE SEATPOST TOO DEEP INTO THE SEAT TUBE CAN DAMAGE THE SEAT TUBE AT THE WHEEL CUT OUT AREA.

Cut the seat tube to size in order to not exceed the maximum insert depth. A Gluing set is added to the seatpost to glue the battery mount in place.

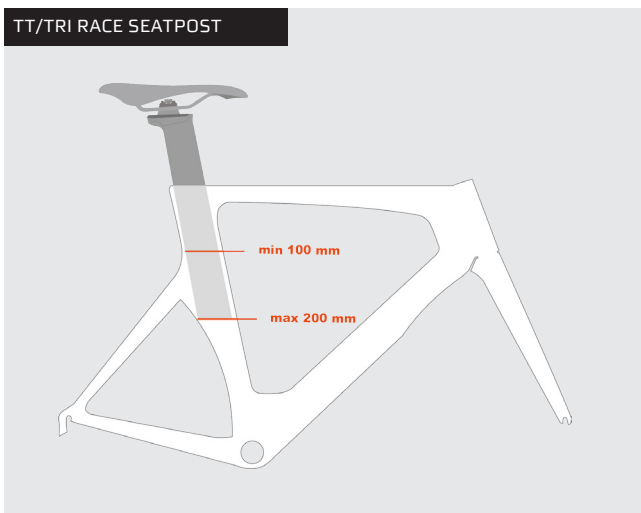

6.3.1 SEAT POST CLAMP

To fix the aero seat post the SPCDEF4ZA001 seat post clamp has to be used. Maximum allowed torque is 10Nm.

6.4. BOTTOM BRACKET

The bottom bracket is designed for press fit 30 cups with a diameter of 46 mm and width of 68 mm. Below bottom bracket cups are being used for the standard assembled bikes.

PART CODE	BRAND	DESCRIPTION	COMPATIBLE CRANKSETS
BBRPF3SRA001	SRAM	PRESS FIT 30 CUPS	SRAM PRESS FIT 30 CRANKSETS
BBRPF3SRA003	SRAM	PRESS FIT 30 TO BSA 68 ADAPTER	SRAM BSA 68 CRANKSETS SHIMANO BSA 68 CRANKSETS
BBRPF3CAM002	CAMPAGNOLO	ULTRA TORQUE™ OS-FIT™ INTEGRATED CUPS BB30 68X46	CAMPAGNOLO ULTRA TORQUE CRANKSETS
BBRPF3CAM003	CAMPAGNOLO	POWER TORQUE™ OS-FIT™ INTEGRATED CUPS BB30 68X46	CAMPAGNOLO POWER TORQUE CRANKSETS
BBRPF3CBE003	C-BEAR	C-BEAR CUPS FOR CAMPAGNOLO ULTRA TORQUE	CAMPAGNOLO ULTRA TORQUE CRANKSETS
BBRPF3CBE005	C-BEAR	C-BEAR CUPS FOR SHIMANO, FSA AND ROTOR 24 MM AXLES	SHIMANO HOLLOWTECH II, FSA MEGA EXO, ROTOR 3D
BBRPF3CBE004	C-BEAR	C-BEAR CUPS FOR CAMPAGNOLO POWER TORQUE	CAMPAGNOLO POWER TORQUE CRANKSETS

6.5. BRAKES

The Dean is suited for most direct mount brakes, available in the market. The image below indicates the bottom bracket direct mount brake mounting positions.

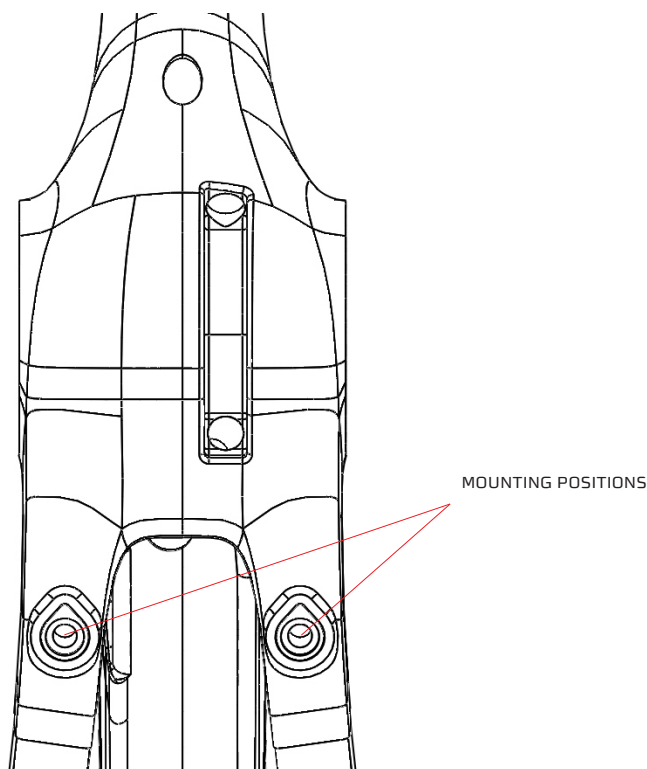

6.6. DERAILLEUR

6.6.1. FRONT

The frame is provided with a bolt on front derailleur clamp (part code: FDCFEC4ZA003).

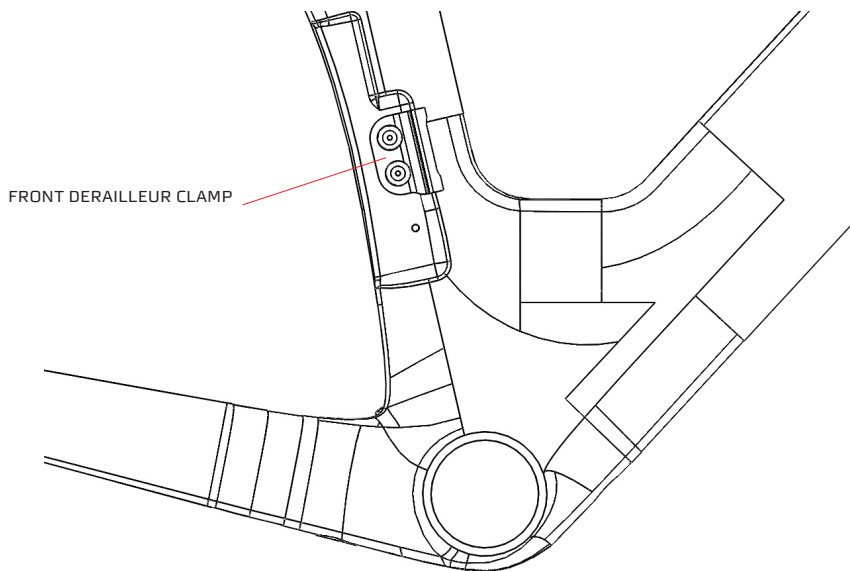

6.6.2. REAR

The hanger used for the Dean comes in two sizes with both a left and right hanger for each size. All dean hangers have a particular part code composed by the letters “HAATIMRID...”, added by 3 numbers. Switching between the dropouts allows to move the rear wheel 5mm relative to the seattube. Each hanger is fixed with three M5 x 10 mm bolts (part code: BLTNOBNOB020).

HANGER TYPE	RIDLEY PART CODE	CHAINSTAY LENGTH MM
SHORT POS. LEFT	HAATIMRID009	395
SHORT POS. RIGHT	HAATIMRID010	395
LONG POS. LEFT	HAATIMRID011	399
LONG POS. RIGHT	HAATIMRID012	399

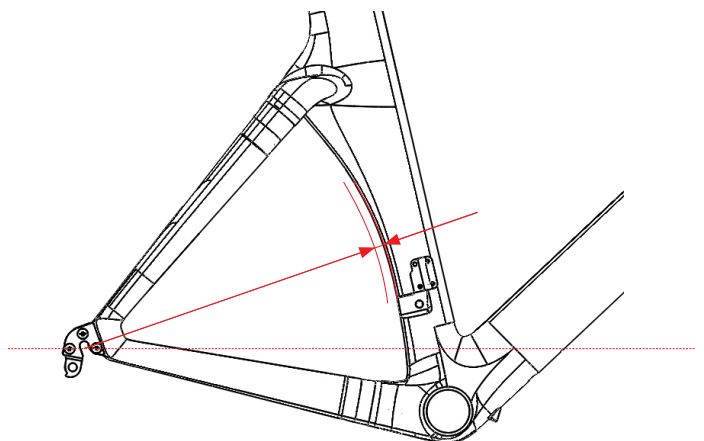

Each hanger is fixed with three M5 x 10 mm bolts (part code: BLTNOBNOB020).



7. WHEELS AND TIRES

7.1 FORK

The fork is developed for 700C race wheels with a build in width of 100 mm and a quick release system with a maximum diameter of 9 mm.

We recommend a maximum tire width of 25 mm with a maximum rim width of 28 mm. Please note that not all tire manufacturers use the same sizing standard so we recommend to do assembly check and confirm clearances.

7.2 FRAME

The frame is developed for 700C race wheels with a build in width of 130 mm and a quick release system with a maximum diameter of 10 mm.

- Frame - wheel clearance
The frame can accommodate wheels with a maximum rim width of 28 mm.
- Frame - tire clearance
The maximum recommended tire width is 28 mm.

8. WARRANTY INFORMATION

8.1 MAXIMUM RIDER WEIGHT

The maximum advised rider weight is 95 kg.

#BeTOUGH