

LIZ ALLOY
FRAME PASSPORT

TYPE: 7DD & 7DE
LAST UPDATE: 05/10/2017

**INDEX**

0. UPDATES.....	3
1. GENERAL.....	3
1.1. Description	3
1.2. Part codes.....	3
2. MATERIAL	3
3. WEIGHT	3
3.1. Frame.....	3
3.2. Fork.....	3
4. GEOMETRY.....	4
5. CABLE ROUTING	4
5.1. Compatibility	4
5.2. Mechanical cable routing.....	4
6. PARTS	5
6.1. Fork.....	5
6.1.1. Material.....	5
6.1.2. Dimensions	5
6.1.3. Wheels.....	5
6.1.4. Part codes	5
6.2. Headset.....	5
6.3. Seat post.....	6
6.4. Bottom bracket	6
6.5. Brakes.....	6
6.6. Derailleur	6
6.6.1. Front.....	6
6.6.2. Rear.....	6
7. WHEELS AND TIRES.....	6
7.1. Frame.....	6
8. WARRANTY INFORMATION.....	6
8.1. Maximum rider weight	6



0. UPDATES

The development of frames, forks and components is a continuous running process. Therefore we strongly advise before reading this information sheet check our website for new updates.

1. GENERAL

1.1. DESCRIPTION

Unique alloy frame with new technical features (Press fit BB30, oversized head tube). The oversized sharp edge tubing guarantees the right amount of stiffness and a high impact resistance. The specially developed flex areas in the seat stays absorb vibrations from the road to give the rider the right amount of comfort. The Liz geometry is especially designed for women. It has a shorter top tube and taller head tube for a more balanced riding position.

1.2. PART CODES

All the Liz 7005 frames have a particular part code composed by the letters "FRAL7RID...", added by 3 numbers. The three numbers change depending on the design and size of the frame. Due to the big amount of frames we don't list all the numbers but you can contact your local dealer for more information if needed.

2. MATERIAL

The Liz 7005 is made of high quality 7005 aluminum.

3. WEIGHT

3.1. FRAME

Ø	Frame Code
42"	FRAL7RID-#>=
44"	FRAL7RID-#>=
46"	FRAL7RID-#>=
...	FRAL7RID-#>=

(*) Weight of painted frame, real weight may differ from the weight mentioned above by 10 %.

3.2. FORK

The weight of the 4ZA Liz 7005 fork is around 560 g (*)

(*) Weight of painted fork, real weight may differ from the weight mentioned above by 10 %.

4. GEOMETRY

SIZE	A	B	C	C'	D	E	F	G	H	I	J*	S	R
XXS	410	450	489	500	130	75,5	70,0	405	67	975	712	519	363
XS	430	470	494	505	135	75	70,0	405	67	978	725	523	362
S	450	490	504	515	140	75	71,0	405	67	980	740	532	370
M	480	520	520	530	155	74,5	72,0	405	67	981	762	550	375

(*) J: Stand over height

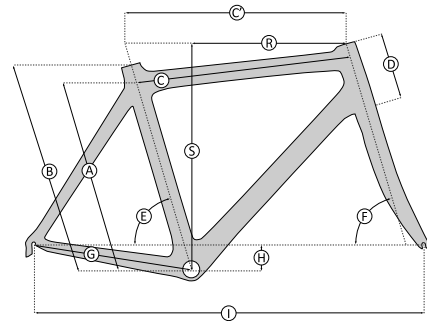

5. CABLE ROUTING

5.1. COMPATIBILITY

The Liz 7005 is compatible for mechanical group sets only.

5.2. MECHANICAL CABLE ROUTING

Below you can see the cable routing of the Liz 7005.

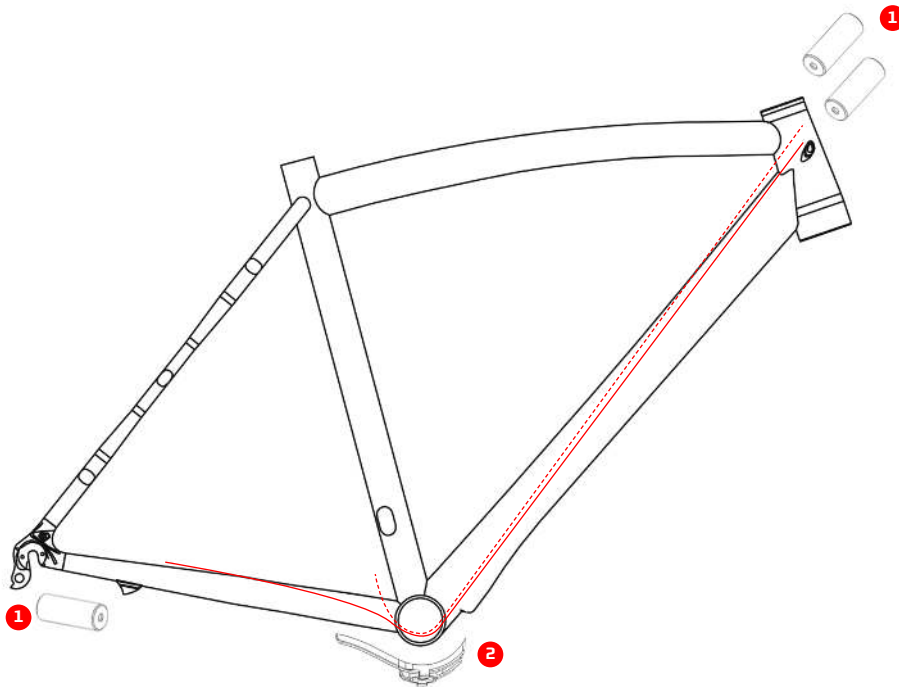

NO.	PART	PART CODE	QUANTITY
1	END CAP	CABSTIJAG002	3
2	CABLE GUIDE	CBGR CERID002	1

6. PARTS

6.1. FORK

The standard fork, used for a Liz 7005, is the 4ZA Liz 7005 fork.

6.1.1. MATERIAL

Fork legs: Carbon
Steerer tube: Alloy

6.1.2. DIMENSIONS

Steerer tube length: 300 mm
Headset: 1 1/8" upper ring – 1 1/2" lower ring
Fork rake: 45 mm
OLD (OverLock nut Distance): 100 mm

6.1.3. WHEELS

The fork is developed for 700C race wheels with a build in width of 100 mm and a quick release system with a maximum diameter of 9 mm.

6.1.4. PART CODES

All the 4ZA Liz 7005 forks have a particular part code composed by the letters "FORCFR4ZA...", added by 3 numbers.

The three numbers, depending on the design. Due to the big amount of forks we don't list all the numbers but you can contact your local dealer for more information if needed.

6.2. HEADSET

45° Oversized angular contact bearing (S.H.I.S.: IS42/28,6|IS52/40):

Lower bearing: 1 1/2"
Upper bearing: 1 1/8"

Recommended headsets:

RIDLEY PART CODE	TYPE	BRAND
HSERACFSA004	NO.42/ACB	FSA
HSERACFSA005	NO.42/CFST/ACB	FSA

6.3. SEAT POST

The Liz 7005 frame is developed to use a 31,6 mm seat post. To fix the seat post the 4ZA 34,9 mm (Part Code: SPCSNG4ZA011) seat post clamp can be used.

6.4. BOTTOM BRACKET

Up to 2014 the Liz featured a bottom bracket designed for press fit 30 cups with a diameter of 46 mm and width of 68 mm. We recommend to only use plastic press fit cups for our frames. The use of metal cups can damage the frame. After 2014 the BB was updated to BSA in a running change.

Below bottom bracket cups are being used for the standard assembled bikes with PF30 BB.

PART CODE	BRAND	DESCRIPTION	CRANKSET
BBRPF3SRA001	SRAM	PRESS FIT 30 CUPS	SRAM PRESSFIT 30 CRANKSETS
BBRPF3SRA003	SRAM	PRESS FIT 30 TO BSA 68 ADAPTER	SRAM BSA 68 CRANKSETS SHIMANO BSA 68 CRANKSETS
BBRPF3CAM002	CAMPAGNOLO	ULTRA TORQUE™ OS-FIT™ INTEGRATED CUPS BB30 68X46	CAMPAGNOLO ULTRA TORQUE CRANKSETS
BBRPF3CAM003	CAMPAGNOLO	POWER TORQUE™ OS-FIT™ INTEGRATED CUPS BB30 68X46	CAMPAGNOLO POWER TORQUE CRANKSETS

2014 and later frames feature a bottom bracket that is BSA threaded and has a width of 68 mm to fit standard BSA68 cups.

6.5. BRAKES

The Liz 7005 is suited for most standard brakes, available in the market.

6.6. DERAILLEUR

6.6.1. FRONT

The frame is designed to use a clamp on derailleur for a 34,9 mm seat tube. Also a braze on derailleur can be used if it's used together with the 4ZA 34,9 mm front derailleur clamp (Part code: FD-CNOB4ZA004).

6.6.2. REAR

The hanger, used for the Liz 7005 is the HAARCERID030.



7. WHEELS AND TIRES

7.1. FRAME

The frame is developed for 700C race wheels with a build in width of 130 mm and a quick release system with a maximum diameter of 10 mm. maximum tire width is 25mm. Please note that not all tire manufacturers use the same sizing standard so we recommend to do assembly check and confirm clearances.

8. WARRANTY INFORMATION

8.1 MAXIMUM RIDER WEIGHT

The maximum advised rider weight is 110 kg.

#BeTOUGH